

# HX16 Pro

Wood chipper



**BRUGGER**

## Powerful gasoline engine!

The HX16 Pro chipper is equipped with a powerful and robust 35 hp RATO gasoline engine with a displacement of 999 cm<sup>3</sup>.

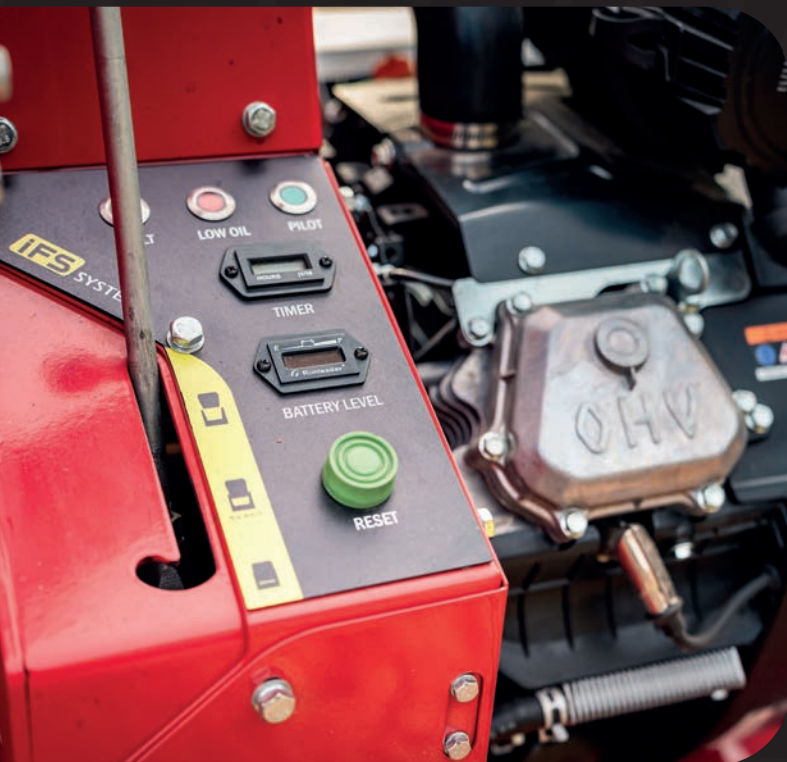

### Features:

- ✓ Log diameter up to 16 cm
- ✓ No-Stress safety system
- ✓ 35 hp Rato gasoline engine
- ✓ Adjustable forward speed
- ✓ 360° rotating chip ejector

### Advantages of the HX16 Pro:



#### Wheeled chassis!

The HX16 PRO is mounted on a chassis equipped with wheels for easy handling and transport to the place of use. The „AL-KO“ chassis can be supplied with road homologation.

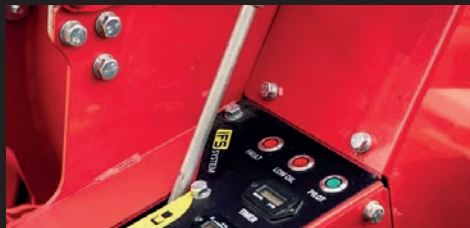

#### Professional control panel

All controls are within easy reach and rationally organised! The HX16 Pro has a control panel on which all important functions are controlled and displayed.



#### NO STRESS system

The chipper is equipped with a hydraulic material retraction system with NO- STRESS safety, which prevents the motor from shutting down in the event of overloading of the machine.

# HX16 Pro

## Wood chipper

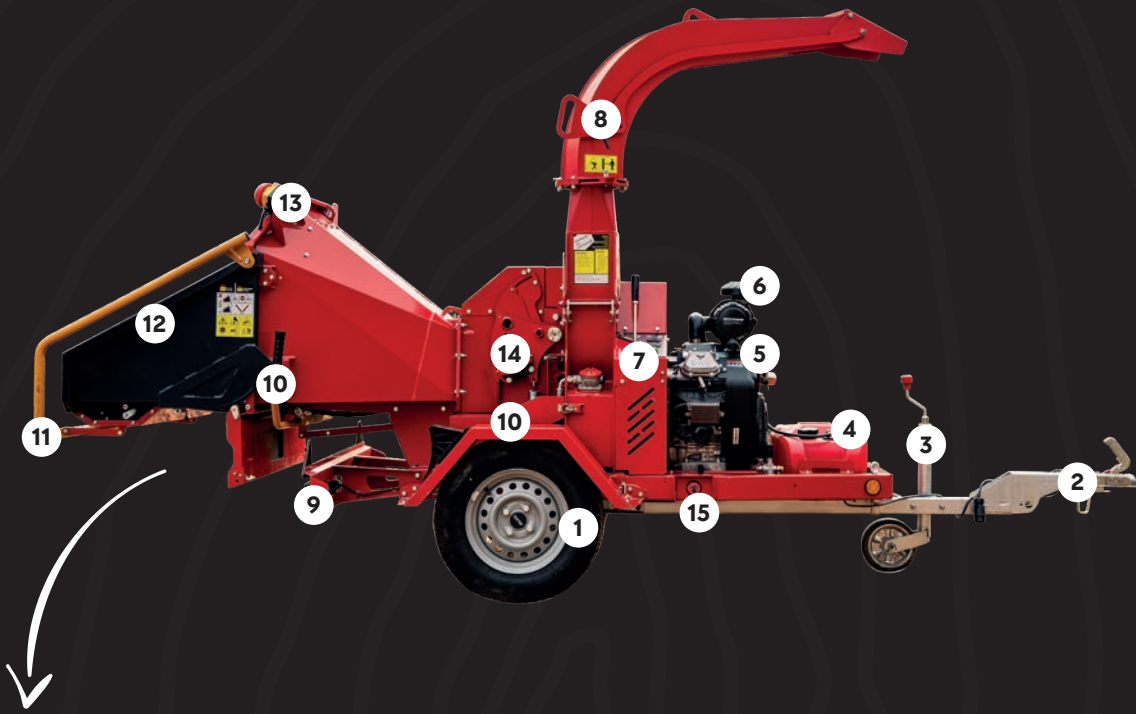

### Components:

- |   |  |  |   |
|---|--|--|---|
| 1. AL-KO wheeled chassis (possible approval for road traffic) | 4. petrol tank                                   | 8. swivelling chipper ejector                  | 12. retractable feed hopper for transport |
| 2. drawbar  | 5. Rato 999cm <sup>3</sup> gasoline engine 35 HP | 9. Lighting system                             | 13. Emergency stop switch                 |
| 3. support wheel  | 6. air filter                                    | 10. forward - reverse retraction control lever | 14. feed roller                           |
|   | 7. control panel and clutch lever                | 11. Input-stop safety bar                      | 15. battery disconnect switch             |

### Technical data:

<b>Manufacturer:</b> Brugger	<b>Max. log diameter:</b> 160 mm
<b>Model:</b> HX16 Pro	<b>Feeding hopper opening:</b> 16,5 x 30 cm
<b>Power supply:</b> Rato gasoline engine PS 35	<b>Chipping drum diameter:</b> 690 mm
<b>Power:</b> 35 CV	<b>Chassis:</b> AL-KO
<b>Displacement:</b> 999 cc	<b>Working configuration dimensions:</b> 3924 x 1390 x 2288 mm
<b>Engine rotation speed:</b> 2800 giri/min	<b>Transport configuration dimensions:</b> 3392 x 1390 x 2288 mm
<b>Number of knives:</b> 2	<b>Fuel tank:</b> 24 L
<b>Feeding:</b> hydraulic (automatic)	<b>Approximative weight:</b> 730 kg

# HX16 Pro

## Wood chipper

The Brugger HX 16 PRO chipper easily processes branches and logs with a **diameter of up to 16 cm**.

It is equipped with a **powerful and robust 35 hp RATO** twin-cylinder petrol engine with a **displacement of 999 cm<sup>3</sup>**.

The HX16 Pro chipper is also equipped with an automatic hydraulic feed system with **no-STRESS protection system**, which prevents the engine from shutting down in the event of an overload.

The Brugger HX16 Pro chipper is designed for professional use. Thanks to its high build quality, robust construction and power, **processing even the hardest and gnarliest wood material** is no problem!

The Brugger HX16 Pro can be used for chipping branches and logs with a **diameter up to 160 mm** that are quickly and effortlessly processed into small fragments and chips.

The chipper is powered by a **powerful 35 hp Rato gasoline engine** and the hydraulic material retraction speed (automatic) can be infinitely adjusted to achieve a feed

The HX16 Pro is built on an AL-KO self-propelled chassis and can also be supplied with approval for driving on public roads. controlled and adaptable to every situation. For this purpose, a sensor measures the rotation speed of the chopping drum. If this drops too low, the feed slows down or stops briefly until the optimum rotation speed is reached again.

The machine requires **little maintenance and all the main points, e.g. the belt, battery, pulleys and blades are easy to reach**. Thanks to simple and intuitive controls intuitive controls, the machine is also recommended for rental.

The HX16 Pro is supplied with an „**AL-KO**“ **chassis and lighting system**, it can therefore be approved for use on public roads.

The chipper has been built to the latest safety standards, making it a safe and reliable machine for everyday use.

You can see a video of the machine in action here:

[www.youtube.com/watch?v=JFzU6is881k](https://www.youtube.com/watch?v=JFzU6is881k)

**For further informations on che machine:**

[www.bruggermachinery.com](http://www.bruggermachinery.com).

Scan the QR CODE and watch the video!



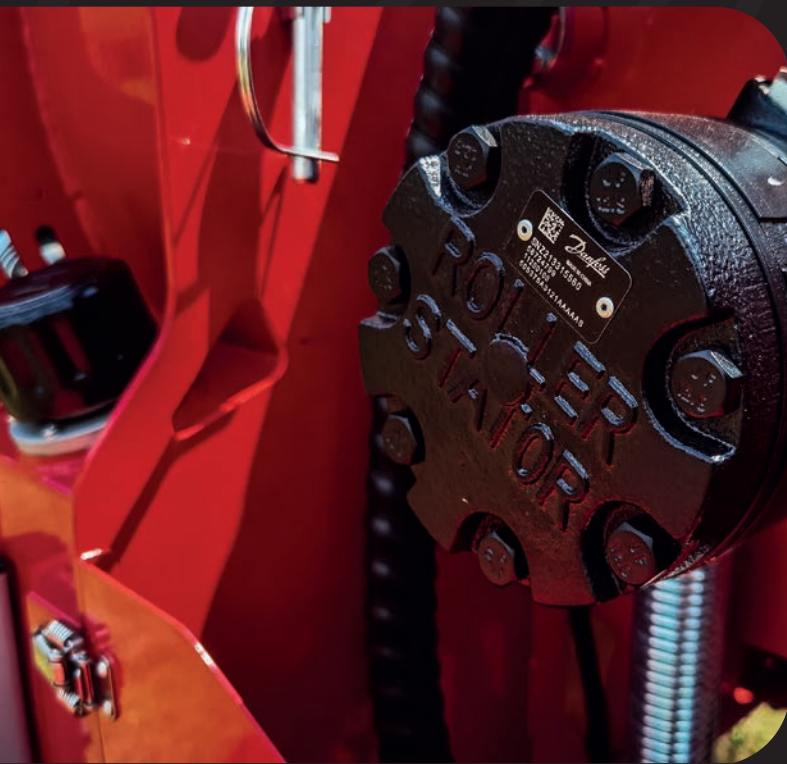

**BRUGGER**

Machinery GmbH



## Chipper HX16 Pro

The HX 16 PRO is the biggest chipper in our product range family.

**€ 13.498,-**

All prices are VAT EXCLUDED



### Pricelist:

Chipper Brugger HX16 Pro	€ 13.498,-
Spare knives set	€ 119,-
Spare counter-blades set	€ 149,-

All prices are VAT EXCLUDED

## Working configuration dimensions:

3924 x 1390 x 2288 mm

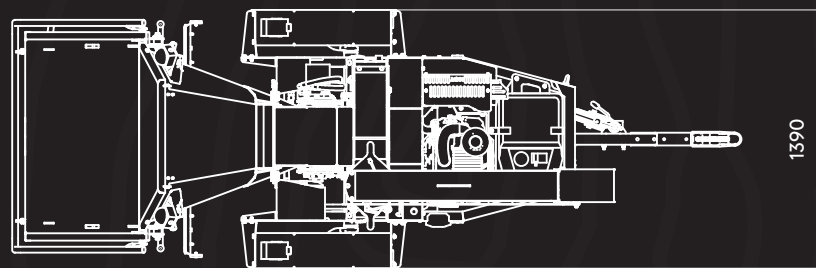
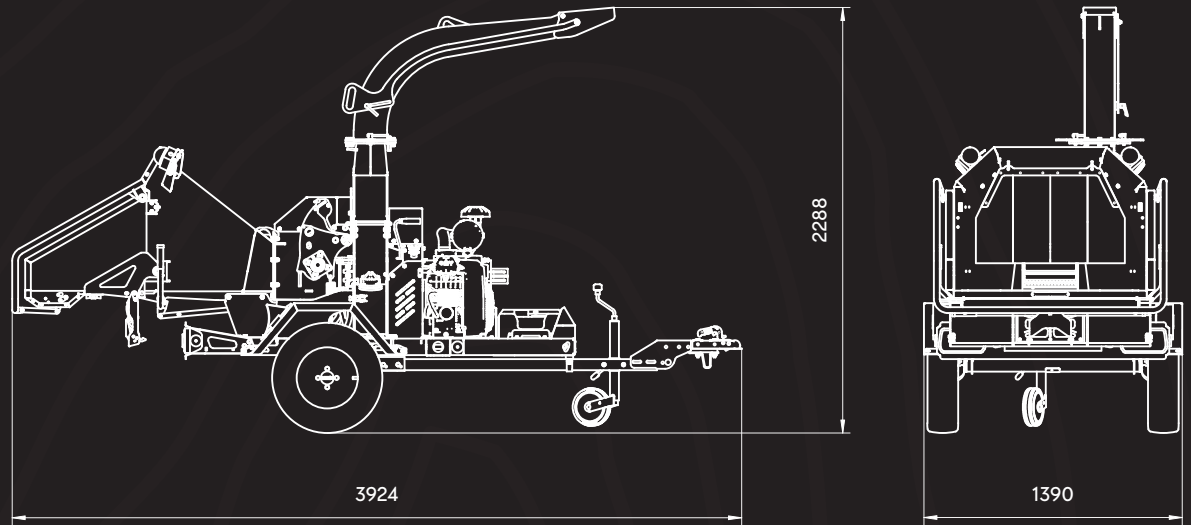

## Transport configuration dimensions:

3392 x 1390 x 2288 mm

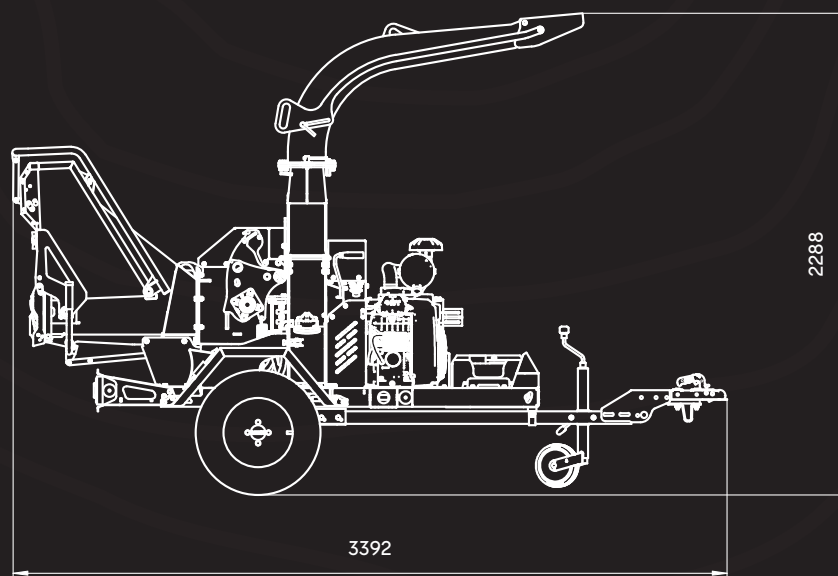

**BRUGGER**

Machinery GmbH



Contact us for a  
customised quote!  
**Call us to request an  
offer!**

# Passion for wood chipper

**BRUGGER**

**Brugger Machinery**

Bacherweg 11  
39030 Gais BZ Italien

Tele: +39 327 397 0120  
Mail: [info@bruggermachinery.com](mailto:info@bruggermachinery.com)  
Web: [www.bruggermachinery.com](http://www.bruggermachinery.com)

The information in this brochure contains information and content that are protected by law.



Version: 1.0 | EN

[www.bruggermachinery.com](http://www.bruggermachinery.com)

