



The Norden System

Accumulators, Tie-Grabbers & Grabbers



Quality small square bale production.

For more than 15 years, we've been hard at work designing, building, testing and retesting on our farm, with unceasing attention to detail, all with one aim: to design the most efficient, labor-minimizing, user-focused bale handling system.

Norden accumulators can easily manage:

35–80 lb bales

32–40 inches long

12 bales per minute

The Norden System is ideal for operations ranging from:

1,000–130,000 bales per year



Efficient.
Labor-minimizing.
User-focused.



KN615: 15 Bale Edge
Tie-Grabber

We understand that you need tools that work hard for your operation. The Norden System is designed to be efficient so that one person can easily move hundreds of bales in a single day. Equipment compatibility is also designed into the system, so you can select the right models to fit your existing equipment and stacking preferences.



AF10 Accumulator (10-Bale Flat)



Bale Squeeze



KN615 Tie-Grabber



510F Grabber

Norden SYSTEM

Norden Accumulator

- Fully automated with no hydraulics or electronics
- Superior handling of high-capacity baler output
- Bales carried gently for cleaner hay
- Performs well on both rolling and flat terrain
- Rust-proof stainless steel deck for easy bale slide
- Bales exit accumulator in a well-aligned bunch
- Tray included for storage of additional twine

Norden Tie-Grabber

- Safer and faster loading and stacking
- Tied groups make more secure loads for transport
- Squeeze bar creates tightly wrapped group
- Knotter consistently makes clean, tight knots
- Twine box holds two balls of twine
- Works with any brand accumulator

Norden Grabber

- Works with any brand accumulator
- Great for unloading and reloading
- Grabs and stacks bales flat or on edge
- Durable 3/16" tubing frame and UHMW bushings
- Powder coated paint resists scratching, rusting
- Adjustable guide bar tightens bale group together
- Cast hooks are easy to mount and replace

Norden Squeeze

- Works with any brand accumulator
- Great for unloading and reloading
- Grabs and stacks bales flat or on edge
- Powder coated paint resists scratching, rusting
- Move as many bales as you can safely lift with your loader
- Requires bales to be tied with an exclusive Norden Tie-Grabber

The Norden System in Action



The **Norden Hay Accumulator** uses gravity and a simple mechanical system to efficiently arrange bales into a group that is then dropped in the field. A **Norden Grabber or Tie-Grabber** mounted on a front-end loader or skid steer picks up the bales to load them onto a waiting truck, trailer or wagon. The groups can then be unloaded into the barn via the grabber without an operator ever needing to touch a bale.

A] The standard stainless steel gate section provides a better surface for bales to slide in higher dirt and moisture conditions.

B] **Norden Accumulators** fit all 14" x 18" two twine bales, and our flat models can also accommodate 16" x 18" two twine bales.

C] As gravity moves the bales downward, the last bale in each row swings a gate to open the next row. The last bale triggers the back gate, and the accumulator unloads its group on the ground, ready for pickup by a tie-grabber or standard grabber. The top-hinged back gate closes as soon as the last bales slide out, ready for the next group.

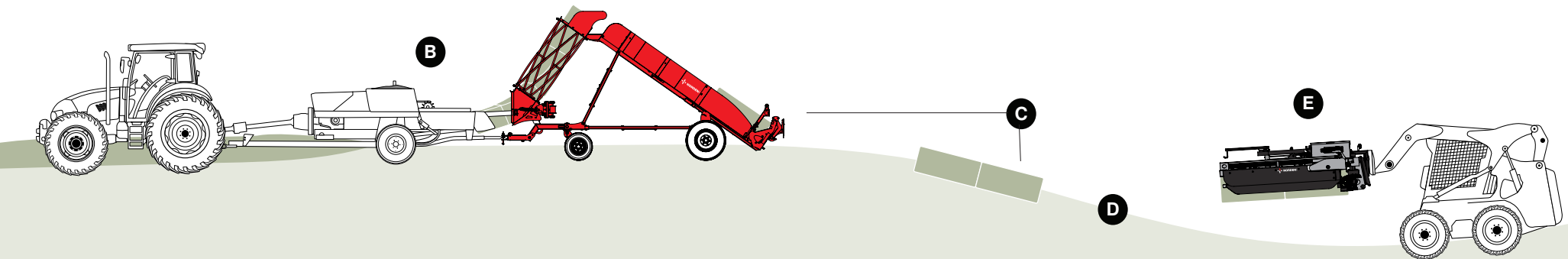

D] **Norden Accumulators** feature a naturally low center of gravity which continues to increase as more bales are added. This attribute makes our accumulators greatly effective for baling on hillsides.

E] The Norden Mfg patented **Tie-Grabber** wraps a string around each group of bales that it picks up.

F] The uniform, tightly wrapped grab gives you peace of mind that your stacks are safely secured on the wagon and in the barn.

G] The system really pays off when you can use your loader to fill your storage. It is just as easy to retrieve the bales when you want to sell or feed them.

H] Use a **Grabber** or **Squeeze** attachment on a Skid Steer, Tractor, Front-end Loader, Telehandler, or Forklift.

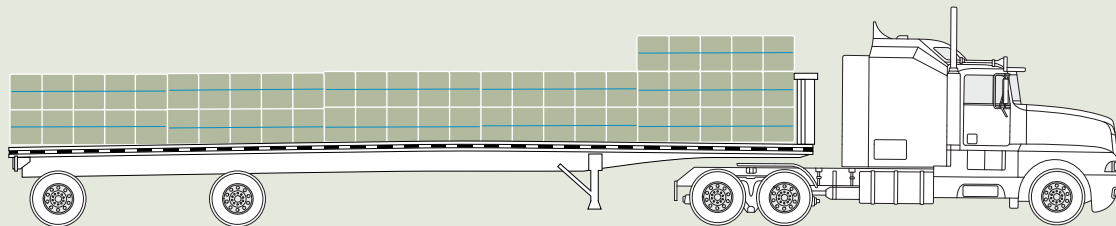
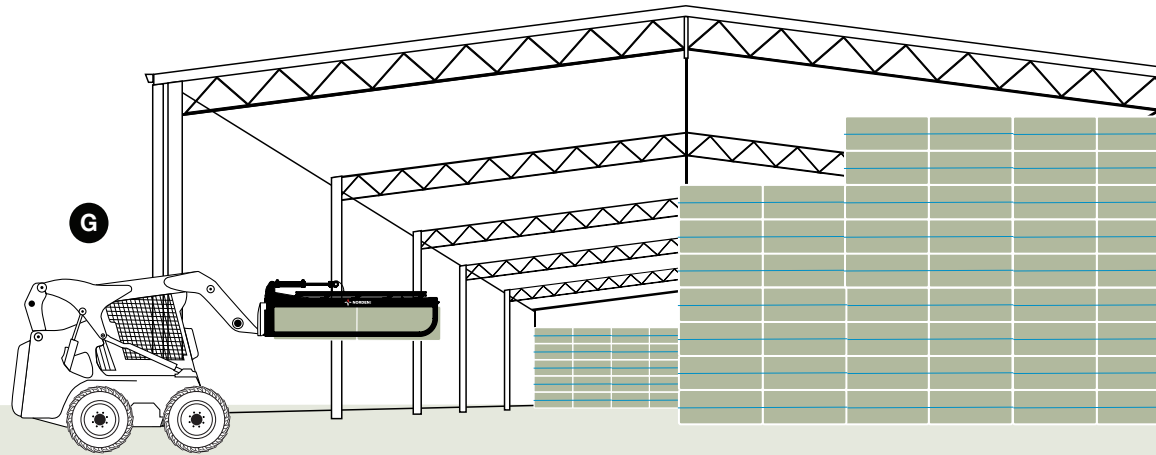
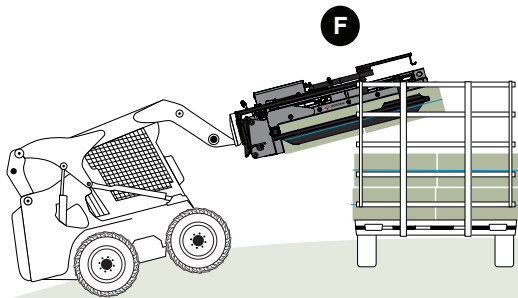

Norden Bale Group Configurations

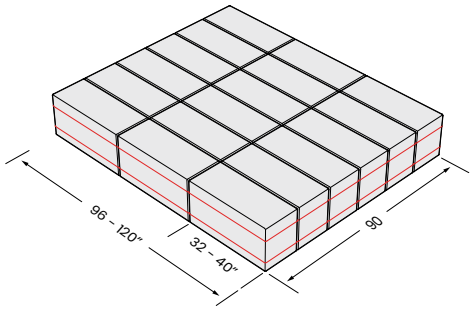

18 Bale Edge Group

- 14 x 18" bales
- 32 - 40" long bales
- 90" wide by 96 - 120" long

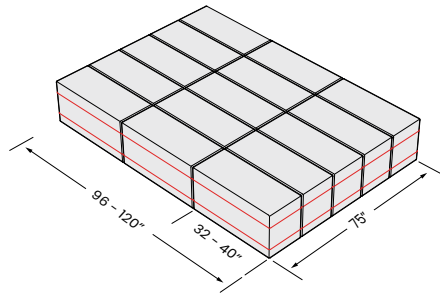

15 Bale Edge Group

- 14 x 18" bales
- 32 - 40" long bales
- 75" wide by 96 - 120" long

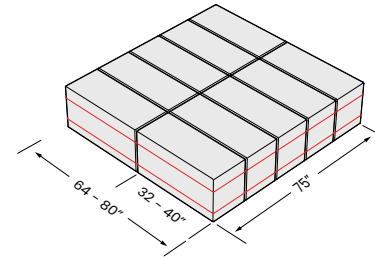

10 Bale Edge Group

- 14 x 18" bales
- 32 - 40" long bales
- 75" wide by 64 - 80" long

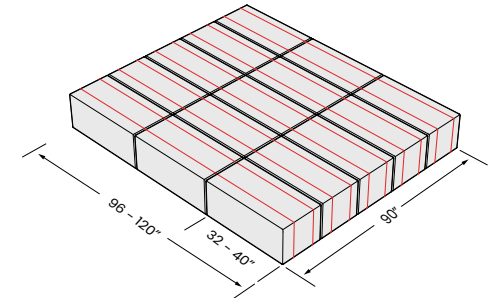

15 Bale Flat Group

- 14 x 18" and 16 x 18" bales
- 32 - 40" long bales
- 90" wide by 96 - 120" long

BALES ON EDGE

BALES FLAT ON STRINGS

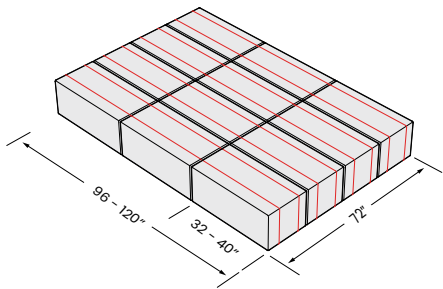

12 Bale Flat Group

- 14 x 18" and 16 x 18" bales
- 32 - 40" long bales
- 72" wide by 96 - 120" long

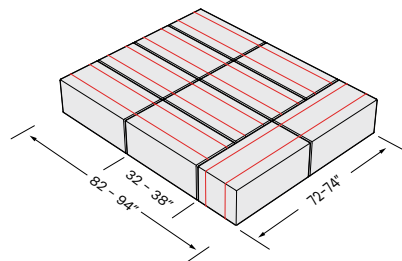

10 Bale Flat Group

- 14 x 18" and 16 x 18" bales
- 32 - 38" long bales
- 72 - 74" wide by 82 - 94" long

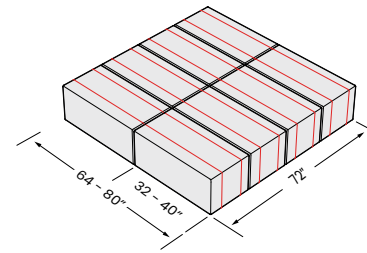

8 Bale Flat Group

- 14 x 18" and 16 x 18" bales
- 32 - 40" long bales
- 72" wide by 64 - 80" long

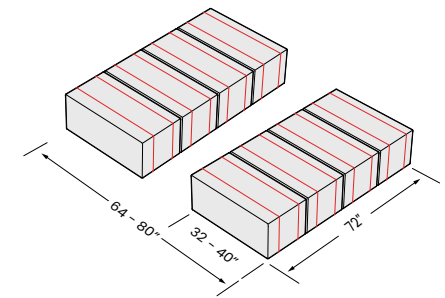

4 Bale Flat Group

- 14 x 18" and 16 x 18" bales
- 32 - 40" long bales
- 72" wide by 64 - 80" long

BALES FLAT ON STRINGS

18 Bale Edge Norden System



AE18: 18 Bale Edge Accumulator

- Great for filling a 9' x 24' wagon
- Perfect for loading van trailers from the rear
- Almost twice as efficient compared to the AE10 and AF10 models
- Same bale group footprint as the AF15 model

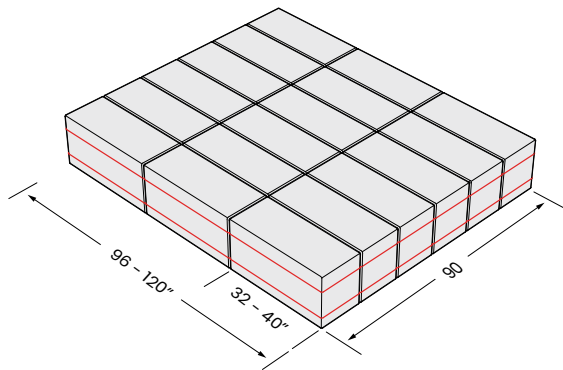

618: 18 Bale Edge Grabber

- Picks up the bales 6 wide and 3 long on edge using 36 hooks on 6 bars
- Handles 14" x 18" bales 32-36" long*
- Requires loader with 2200 lb lift capacity**



KN618: 18 Bale Edge Tie-Grabber

- Picks up the bales 6 wide and 3 long on edge using 36 hooks on 6 bars
- Handles 14" x 18" bales 32-36" long*
- Requires loader with 2600 lb lift capacity**



WORKS WITH

SQ102: Edge Bale Squeeze

- Picks up tied bundles that are 4, 5, or 6 bales wide and 3 bales long
- For maximum efficiency, it is recommended to pick up as many bales as the loader can safely handle
- 4000 lb max lift capacity

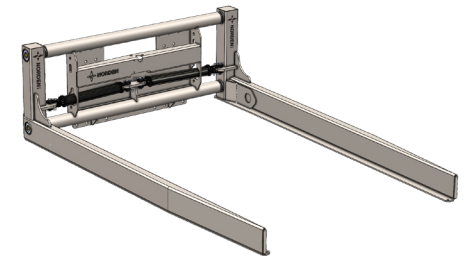

* With no adjustments. An extended version is available for bales longer than 36".

** Lift capacity is an estimate based on an average bale weight of 40-50 pounds. However, it is up to the individual to determine their specific loader requirements.

15 Bale Edge Norden System



AE15: 15 Bale Edge Accumulator

- Perfect arrangement for filling a 9' x 20' wagon
- One-third more efficient compared to the AE10 and AF10 models
- Same bale group footprint as the AF12

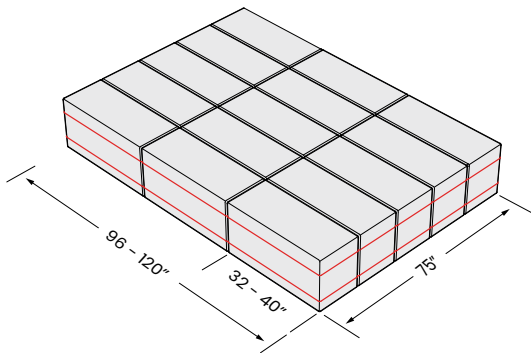

615: 15 Bale Edge Grabber

- Picks up the bales 5 wide and 3 long on edge using 30 hooks on 6 bars
- Handles 14"x18" bales 32-36" long*
- Requires loader with 1900 lb lift capacity**



KN615: 15 Bale Edge Tie-Grabber

- Picks up the bales 5 wide and 3 long on edge using 30 hooks on 6 bars
- Handles 14" x 18" bales 32-36" long*
- Requires loader with 2400 lb lift capacity**

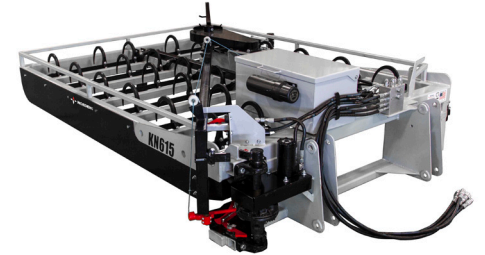

WORKS WITH

SQ102: Edge Bale Squeeze

- Picks up tied bundles that are 4, 5, or 6 bales wide and 3 bales long
- For maximum efficiency, it is recommended to pick up as many bales as the loader can safely handle
- 4000 lb max lift capacity

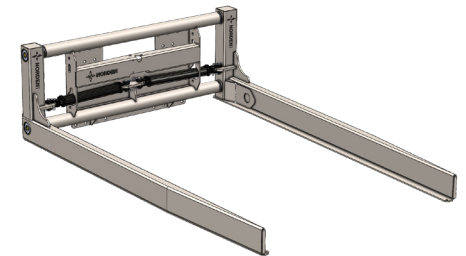

* With no adjustments. An extended version is available for bales longer than 36".

** Lift capacity is an estimate based on an average bale weight of 40-50 pounds. However, it is up to the individual to determine their specific loader requirements.

10 Bale Edge Norden System



AE10: 10 Bale Edge Accumulator

- Well suited for small farms
- Lower lifting capacity requirements
- Bales measuring 36" long, may be cross stacked with the 510 Grabber

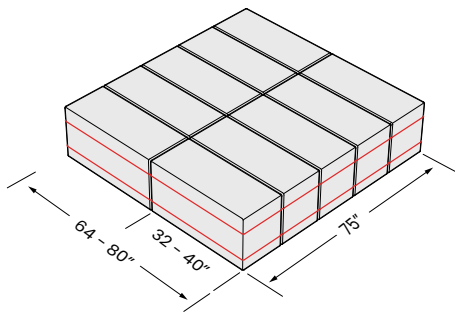

510: 10 Bale Edge Grabber

- Picks up the bales 5 wide and 2 long on edge using 25 hooks on 5 bars
- The 10 bale edge group can be picked up from any side of the group
- Handles 14"x18" bales 32-36" long*
- Requires loader with 1500 lb lift capacity**



KN510: 10 Bale Edge Tie-Grabber

- Picks up the bales 5 wide and 2 long on edge using 25 hooks on 5 bars
- The 10 bale edge group can be picked up from any side of the group
- Handles 14" x 18" bales 32-36" long*
- Requires loader with 1800 lb lift capacity**



WORKS WITH

SQ72: Edge Bale Squeeze

- Picks up tied bundles that are 4, 5, or 6 bales wide and 2 bales long
- For maximum efficiency, it is recommended to pick up as many bales as the loader can safely handle
- 4000 lb max lift capacity

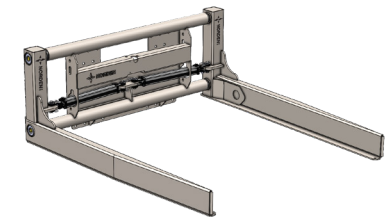

* With no adjustments. An extended version is available for bales longer than 36".

** Lift capacity is an estimate based on an average bale weight of 40-50 pounds. However, it is up to the individual to determine their specific loader requirements.

15 Bale Flat Norden System



AF15: 15 Bale Flat

- Great for filling a 9' x 24' wagon
- Perfect for loading van trailers from the rear
- Our largest configuration for bales on their strings
- Same bale group footprint as the AE18

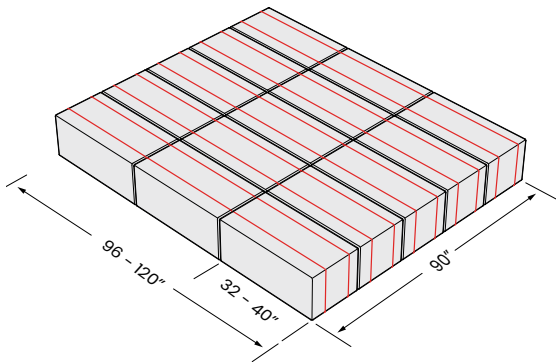

615F: 15 Bale Flat Grabber

- Picks up the bales 5 wide and 2 long on edge using 25 hooks on 5 bars
- The 10 bale edge group can be picked up from any side of the group
- Handles 14"x18" bales 32-36" long*
- Requires loader with 1500 lb lift capacity**



KN615F: 15 Bale Flat Tie-Grabber

- Pick up the bales 5 wide and 3 long on their strings using 30 hooks on 6 bars
- Handles 14" x 18" and 16" x 18" bales 32-36" long*
- Requires loader with 2500 lb lift capacity**



WORKS WITH

SQ102: 18 Bale Edge Bale Squeeze

- Picks up tied bundles that are 4, 5, or 6 bales wide and 3 bales long
- For maximum efficiency, it is recommended to pick up as many bales as the loader can safely handle
- 4000 lb max lift capacity

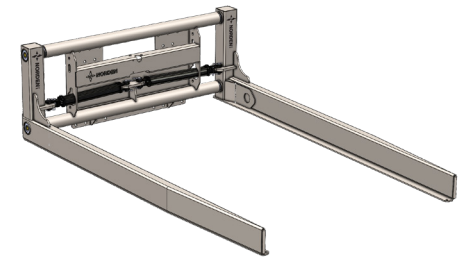

* With no adjustments. An extended version is available for bales longer than 36".

** Lift capacity is an estimate based on an average bale weight of 40-50 pounds. However, it is up to the individual to determine their specific loader requirements.

12 Bale Flat Norden System



AF12: 12 Bale Flat

- Well-suited for filling a 9' x 20' wagon
- A popular choice for accumulating bales on their strings
- Same bale group footprint as the AE15

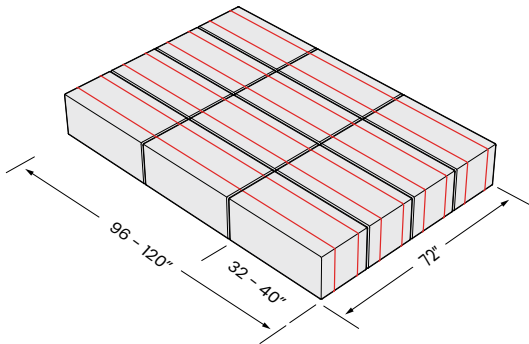

612F: 12 Bale Flat Grabber

- Picks up the bales 4 wide and 3 long on their strings using 24 hooks on 6 bars
- Handles 14" x 18" and 16" x 18" bales 32-36" long*
- Requires loader with 1800 lb lift capacity**



KN612F: 12 Bale Flat Tie-Grabber

- Picks up the bales 4 wide and 3 long on their strings using 24 hooks on 6 bars
- Handles 14" x 18" and 16" x 18" bales 32-36" long*
- Requires loader with 2300 lb lift capacity**

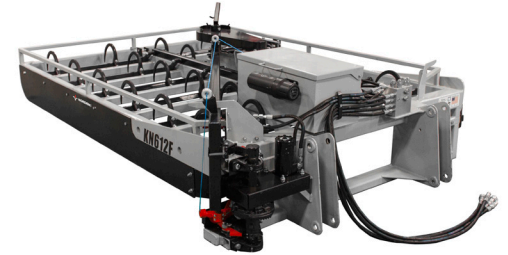

WORKS WITH

SQ102: Edge Bale Squeeze

- Picks up tied bundles that are 4, 5, or 6 bales wide and 3 bales long
- For maximum efficiency, it is recommended to pick up as many bales as the loader can safely handle
- 4000 lb max lift capacity

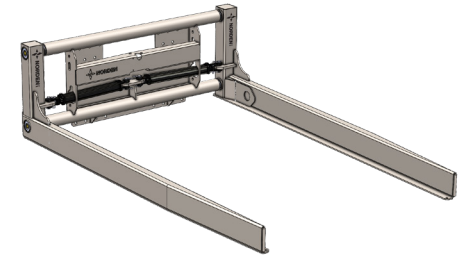

* With no adjustments. An extended version is available for bales longer than 36".

** Lift capacity is an estimate based on an average bale weight of 40-50 pounds. However, it is up to the individual to determine their specific loader requirements.

10 Bale Flat Norden System



AF10: 10 Bale Flat

- The arrangement of 2.5 rows of bales fits perfectly on a 8' wagon side-to-side
- Our most popular accumulator
- Well suited for small farms
- The tie row allows for cross-stacking on wagon with the KN510F tie-grabber or 510F grabber, for a more stable load

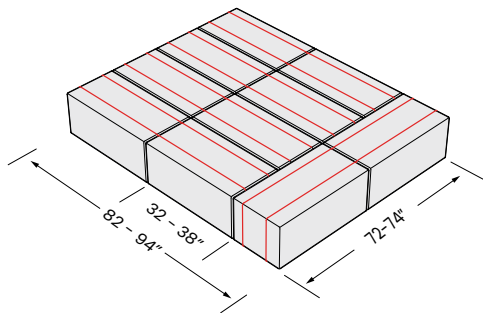

510F: 10 Bale Flat Grabber

- Picks up the bales on their strings 4 wide and 2 long, plus a tie row with 2 bales turned sideways, using 27 hooks on 5 bars
- Handles 14" x 18" and 16" x 18" bales 32-38" long*
- Requires loader with 1700 lb lift capacity**



KN510F: 10 Bale Flat Tie-Grabber

- Picks up the bales on their strings 4 wide and 2 long, plus a tie row with 2 bales turned sideways, using 27 hooks on 5 bars
- Handles 14" x 18" and 16" x 18" bales 32-38" long*
- Requires loader with 1900 lb lift capacity**
- Pick up the bales from either the 2 or 4-bale side



WORKS WITH

SQ90: Edge Bale Squeeze

- Picks up tied bundles that are 4, 5, or 6 bales wide and 2.5 bales long
- For maximum efficiency, it is recommended to pick up as many bales as the loader can safely handle
- 4000 lb max lift capacity

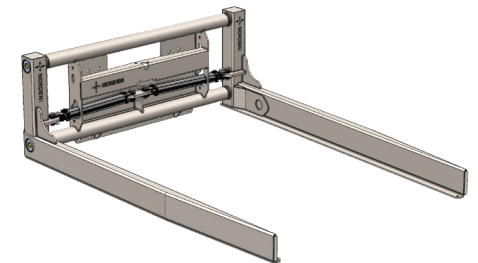

* With no adjustments. An extended version is available for bales longer than 36".

** Lift capacity is an estimate based on an average bale weight of 40-50 pounds. However, it is up to the individual to determine their specific loader requirements.

8 Bale Flat Norden System



AF8: 8 Bale Flat

- Excellent for smaller operations
- Bales measuring 36" long, may be cross stacked with the 408F Grabber

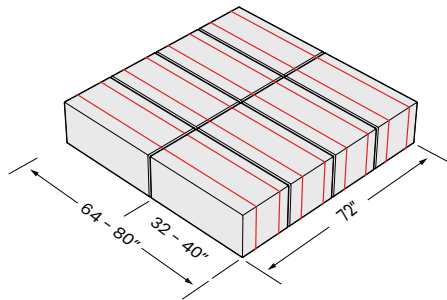

408F: 8 Bale Flat Grabber

- Picks up the bales 4 wide and 2 long on their strings using 16 hooks on 4 bars.
- Handles 14" x 18" and 16" x 18" bales 32-36" long*
- Requires loader with 1400 lb lift capacity**



KN408F: 8 Bale Flat Tie-Grabber

- Picks up the bales 4 wide and 2 long on their strings using 16 hooks on 4 bars
- Handles 14" x 18" and 16" x 18" bales 32-36" long*
- Requires loader with 1700 lb lift capacity**



WORKS WITH

SQ72: Edge Bale Squeeze

- Picks up tied bundles that are 4, 5, or 6 bales wide and 2 bales long
- For maximum efficiency, it is recommended to pick up as many bales as the loader can safely handle
- 4000 lb max lift capacity

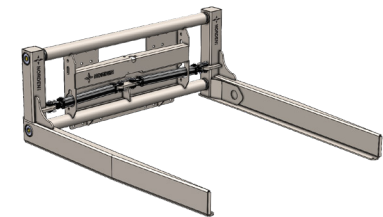

* With no adjustments. An extended version is available for bales longer than 36".

** Lift capacity is an estimate based on an average bale weight of 40-50 pounds. However, it is up to the individual to determine their specific loader requirements.

4 Bale Flat Norden System



AF4: 4 Bale Flat

- Our smallest accumulator
- Recommended for operations of less than 5000 bales-per-year
- Bales measuring 36" long may be cross stacked with the EGF8 grabber

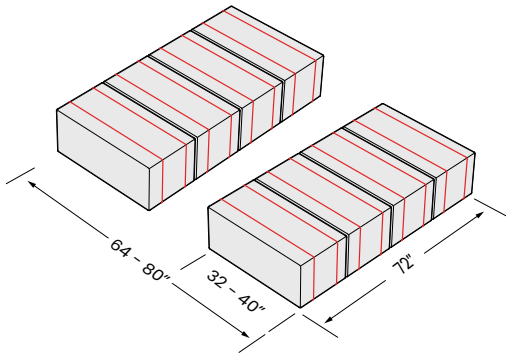

EGF8: 8 Bale Flat Grabber

- Picks up the bales on their strings 4 wide and 2 long, using 16 hooks on 4 bars
- Handles 14" x 18" and 16" x 18" bales 32-36" long*
- The two bale length allows for narrower wagons or for longer bales than models that arrange the bales 3 long
- Skidsteer quick attach brackets and 6' hydraulic hoses are standard
- Requires loader with 1150 lb lift capacity**



* With no adjustments. An extended version is available for bales longer than 36".

** Lift capacity is an estimate based on an average bale weight of 40-50 pounds. However, it is up to the individual to determine their specific loader requirements.



Maximizing time for even small acreage growers.

The 4 Bale Flat System is uniquely designed for growers baling less than 5,000 bales-per-year. The AF4 Accumulator and EGF8 Grabber team up to provide the same great experience expected of Norden Systems but at a much lower initial investment than our full-sized models.

The AF4 accumulates in groups of 4 bales at a speed of up to 12 bales per minute. The EGF8 grabber picks up two of these 4 bale groups and stacks them on a wagon in 8 bale groups. The EGF8 is light enough at just 415 pounds that it can be paired with a utility tractor or small skid loader for loading and unloading.

Norden Accumulator Bale Length Recommendations

Models AF4–AE18 (except AF10, see below)

32"	33"–38"	39"–40"	41"
Edge of recommended	Typical bale lengths, use standard grabber	Extended grabber optimal	Edge of recommended

Model AF10

32"	33"–37"	38"	<i>AF10's unique bale arrangement not conducive to longer bales</i>
-----	---------	-----	---

System	Models	Shipping Dimensions	Working Dimensions	Approximate Weight	Bale Size	Group Size	Lift Capacity Requirement**
18 Bale Edge	AE18 Accumulator	24'8"L x 9'4"W x 5'7"H	24'7"L x 9'4"W x 12'7"H	3030 lb	14" x 18" x 32-40"	90" W x 96-120"L	•
	618 Grabber	105"L x 89"W x 22"H	95" L x 87.5"W	840 lb	14" x 18" x 32-36"*	•	2600 lb
	KN618 Tie-Grabber	109"L x 95"W x 30"H	95" L x 87.5"W	1540 lb	14" x 18" x 32-36"*	•	2600 lb
	SQ102 Squeeze	107" L x 74" W x 29" H	101" L x 67.5-103.5" W x 29" H	1060 lb	•	72-90" W x 96-108" L	•
15 Bale Edge	AE15 Accumulator	21'6"L x 7'10"W x 5'7"H	21'5"L x 7'10"W x 11'1"H	2480 lb	14" x 18" x 32-40"	75"W x 96-120"L	•
	615 Grabber	105"L x 72"W x 22"H	95"L x 72"W	780 lb	14" x 18" x 32-36"*	•	1900 lb
	KN615 Tie-Grabber	109"L x 78"W x 30"H	95"L x 72"W	1480 lb	14" x 18" x 32-36"*	•	2400 lb
	SQ102 Squeeze	107" L x 74" W x 29" H	101" L x 67.5-103.5" W x 29" H	1060 lb	•	72-90" W x 96-108" L	•
10 Bale Edge	AE10 Accumulator	17'5"L x 7'10"W x 5'7"H	17'4"L x 7'10"W x 9'2"H	2130 lb	14" x 18" x 32-40"	75"W x 64-80"L	•
	510 Grabber	82"L x 72"W x 22"H	72"L x 72"W	680 lb	14" x 18" x 32-36"*	•	1500 lb
	KN510 Tie-Grabber	86"L x 78"W x 30"H	72"L x 72"W	1380 lb	14" x 18" x 32-36"*	•	1800 lb
	SQ72 Squeeze	77" L x 74" W x 29" H	71" L x 67.5-103.5" W x 29" H	950 lb	•	72-90" W x 96-108" L	•
15 Bale Flat	AF15 Accumulator	21'10"L x 9'4"W x 5'7"H	21'9"L x 9'4"W x 11'5"H	2740 lb	14-16" x 18" x 32-40"	90"W x 96-120"L	•
	615F Grabber	105"L x 89"W x 22"H	95"L x 87.5"W	815 lb	14-16" x 18" x 32-36"*	•	2100 lb
	KN615F Tie-Grabber	109"L x 95"W x 30"H	95"L x 87.5"W	1515 lb	14-16" x 18" x 32-36"*	•	2500 lb
	SQ102 Squeeze	107" L x 74" W x 29" H	101" L x 67.5-103.5" W x 29" H	1060 lb	•	72-90" W x 96-108" L	•
12 Bale Flat	AF12 Accumulator	21'2"L x 7'10" W x 5'7"H	21'1"L x 7'10" W x 11'1"H	2290 lb	14-16" x 18" x 32-40"	72"W by 96-120"L	•
	612F Grabber	105"L x 72"W x 22"H	95"L x 72"W	760 lb	14-16" x 18" x 32-36"*	•	1800 lb
	KN612F Tie-Grabber	109"L x 78"W x 30"H	95"L x 72"W	1460 lb	14-16" x 18" x 32-36"*	•	2300 lb
	SQ102 Squeeze	107" L x 74" W x 29" H	101" L x 67.5-103.5" W x 29" H	1060 lb	•	72-90" W x 96-108" L	•
10 Bale Flat	AF10 Accumulator	18'11"L x 7'10"W x 5'7"H	18'10"L x 7'10"W x 10'1"H	2240 lb	14-16" x 18" x 32-38"	72-74"W x 82-94"L	•
	510F Grabber	100"L x 72"W x 22"H	90"L x 72"W	740 lb	14-16" x 18" x 32-40"*	•	1700 lb
	KN510F Tie-Grabber	104"L x 78"W x 30"H	90"L x 72"W	1440 lb	14-16" x 18" x 32-40"*	•	1900 lb
	SQ90 Squeeze	95" L x 74" W x 29" H	89" L x 67.5-103.5" W x 29" H	1020 lb	•	72-90" W x 96-108" L	•
8 Bale Flat	AF8 Accumulator	17'1"L x 7'10"W x 5'7"H	17'L x 7'10"W x 9'2"H	2010 lb	14-16" x 18" x 32-40"	72"W by 64-80"L	•
	408F Grabber	82"L x 72"W x 22"H	72"L x 72"W	580 lb	14-16" x 18" x 32-36"*	•	1400 lb
	KN408F Tie-Grabber	86"L x 78"W x 30"H	72"L x 72"W	1280 lb	14-16" x 18" x 32-36"*	•	1700 lb
	SQ72 Squeeze	77" L x 74" W x 29" H	71" L x 67.5-103.5" W x 29" H	950 lb	•	72-90" W x 96-108" L	•
4 Bale Flat	AF4 Accumulator	12'11"L x 7'4"W x 7'5"H	12'11"L x 7'4"W x 7'5"H	1232 lb	14-16" x 18" x 32-40"	72"W x 64-80"L	•
	EGF8 Grabber	78"L x 71"W x 21"H	72"L x 72"W	415 lb	14-16" x 18" x 32-36"*	•	1150 lb

Norden Tie-Grabbers come standard with a single hydraulic circuit. A two-circuit connection is available upon request.

* With no adjustments. An extended version is available for bales longer than 36".

** Lift capacity is an estimate based on an average bale weight of 40-50 pounds. However, it is up to the individual to determine their specific loader requirements.





Norden Mfg
4210 Kinsman Rd. NW
North Bloomfield, OH 44450
877-296-5851
sales@nordenmfg.com
www.nordenmfg.com